



Appendix B – Roll Cage Construction

These rules are effective **March 15 2014** and will remain valid until they are replaced with an updated document.

Table of Contents

1 Roll Cage Choice of Specifications.....	2
2 Roll Cage General Requirements.....	2
2.1 Required Element 1 - Main Roll Cage Structure & Backstays.....	2
2.2 Required Element 2 - Roof Bars.....	3
2.3 Required Element 3 - Backstay Diagonals.....	3
2.4 Required Element 4 - Main Hoop Diagonal Members.....	4
2.5 Required Element 5 - Sill bars.....	5
2.6 Required Element 6 - A-pillar reinforcement.....	6
2.7 Required Element 7 - Door Bars.....	6
2.7.1 253-9 - X Configuration.....	6
2.7.2 253-10 - V Configuration.....	7
2.7.3 253-11 - Configuration with single straight bar with sill bar.....	7
2.7.4 Stock-car style configuration bar.....	7
3 Optional Reinforcement of the Roll cage.....	7
3.1 Optional Reinforcing Members.....	7
3.2 Reinforcement to the Vehicle Body.....	8
3.3 Front core support reinforcement.....	8
3.4 Trunk area reinforcement.....	8
4 Detailed Construction Specifications.....	9
4.1 Mounting of Roll cages to the Body shell.....	9
4.1.1 Welded Connections.....	9
4.1.2 Bolted Connections.....	9
4.1.3 Reinforcement plates.....	9
4.1.4 Double Through Plating.....	9
4.2 Gusset construction.....	10
4.3 Removable Members.....	10
4.4 Guidance on Welding.....	10
4.5 Cage Tubing Material Requirements.....	10
4.6 Cage Tubing Size Requirements.....	10
5 Protective Padding.....	11
5.1 Required Padding.....	11
5.2 Recommended Padding.....	11
6 Grandfathering and Variances.....	11
7 Documentation and Inspection.....	12

1 Roll Cage Choice of Specifications

Roll cages are mandatory for all vehicles. Several specifications for rollcages may be used:

- 1 An FIA approved roll cage (with either FIA homologation certificates or ASN homologation certificates). The homologation of any such rollcage must be current with the date of logbook issue. Cages for cars competing in FIA rally classes must use a homologated cage correct for the FIA class. Cages falling into this category must exactly meet their FIA specifications, be unmodified from those specifications, and are not subject to the remainder of the rules in this appendix.
- 2 Rollcages built to the FIA specification Article 253, Appendix J.
- 3 Cages built to the NASA Rally Sport specifications listed below.

Alternately, if the vehicle is presenting under alternate technical regulations as per GRR 3.8.14, consult the appropriate documents.

2 Roll Cage General Requirements

A roll cage must be designed and made so that, when correctly installed, it substantially reduces body shell deformation and so reduces the risk of injury to occupants.

The essential features of roll cages are sound construction, designed to suit the particular vehicle and the drivers' physical statures, adequate mountings, adequate padding, and a close fit to the body shell.

Tubes must not carry fluids or exhaust.

The roll cage must not unduly impede the entry or exit of the driver and co-driver.

Interior trim may be modified to the extent necessary to facilitate proper roll cage installation.

A roll cage consists of 7 elements. New cage construction requires that all 7 elements be in place.

2.1 Required Element 1 - Main Roll Cage Structure & Backstays

There is a choice of four options for the layout of the main tubes that surround the occupants.

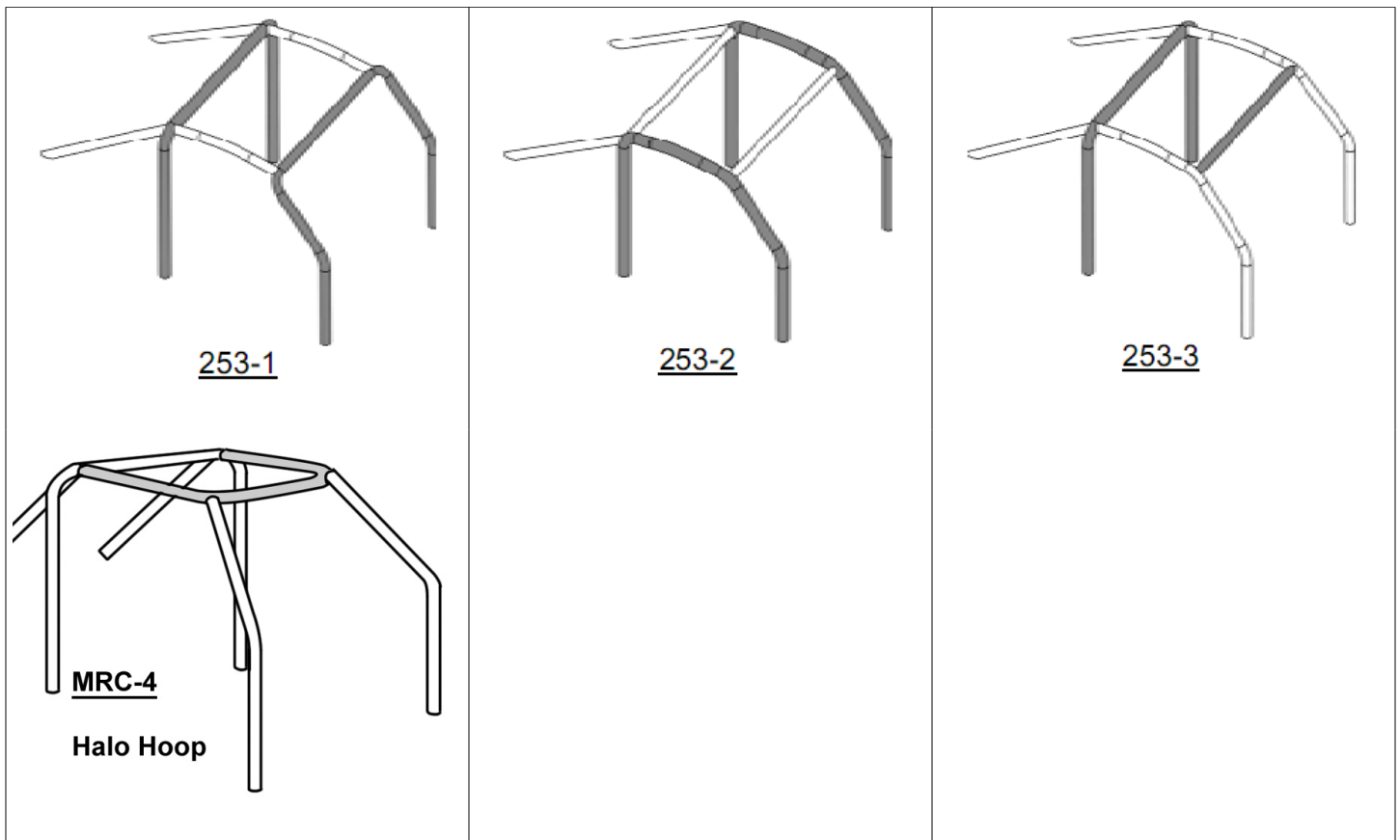

1. 353-1 - A main rollbar, a front rollbar, and connectors.

2. 253-2 - Two lateral rollbars and connectors.
3. 253-3 - A main rollbar, 2 lateral half rollbars, and connectors. This arrangement is the most usual.
4. MRC-4 – A main rollbar, a halo hoop, and 2 front down bars.

The backstays must be attached near the roofline and near the top outer bends of the main rollbar or lateral rollbars, on both sides of the car. They must make an angle of at least 30° relative to a vertical plane, must run rearwards, must be straight, and be placed as close as practical to the interior side panels of the body shell. Although not required to do so, the backstays usually connect to the rear strut towers.

These rollbars must be made in one piece without joints. Their construction must be smooth and even, without ripples or cracks. The tubing must be bent by a cold working process.

The vertical part of the main rollbar, or rear legs of a lateral roll bar, must be as straight as possible and as close as possible to the interior contour of the body shell.

The front portions of a front rollbar, or of a lateral rollbar or lateral half rollbar, must follow the A pillars. The portion from the base of the windshield opening to the floor must be vertical.

2.2 Required Element 2 - Roof Bars

There is a choice of four options within this element.

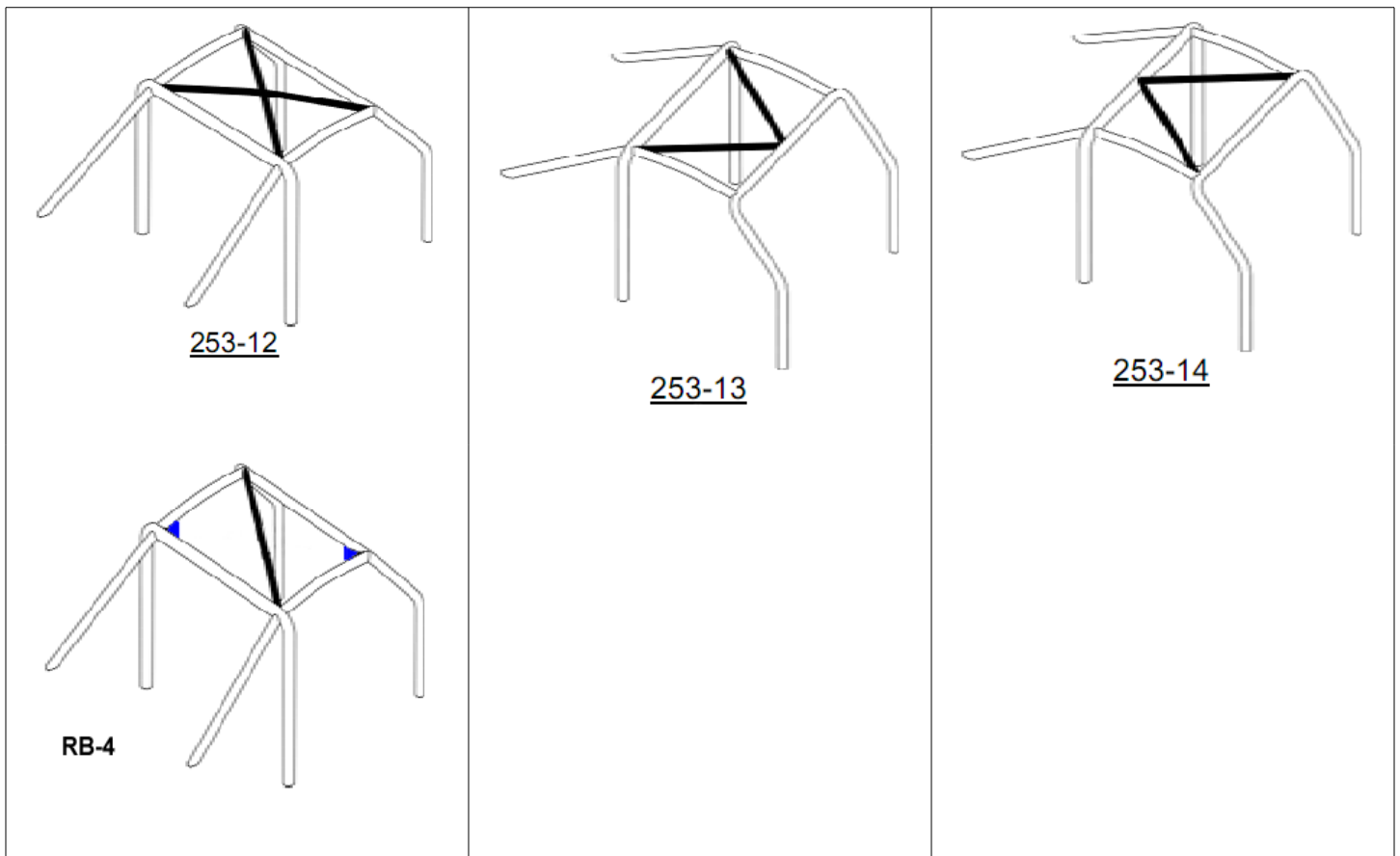

Choice RB-4 requires one gusset in the plane of the roof at each of the locations marked in blue on the diagram. The diagonal can start from either front side.

Bars may be slightly bowed to follow the contour of the roof.

Choice 253-14, if chosen, must be used with Backstay Diagonal choice 253-22.

2.3 Required Element 3 - Backstay Diagonals

There is a choice of three options within this element.

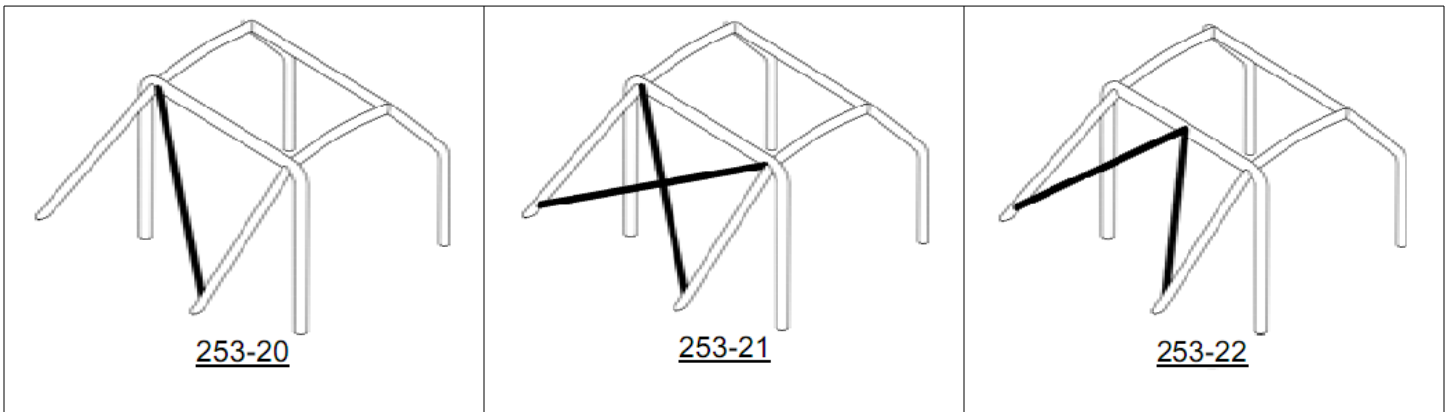

For choice 253-21 it is required that one of the diagonals in an X-configuration in the plane of the backstays be a continuous tube, and that the junction be gusseted.

Choice 253-22, if chosen, must be used with Roof Bar choice 253-14.

For choices 253-20 and 253-21, the upper end of the diagonal(s) must join the upper end of a backstay no more than 4 inches from its junction with the main rollbar or with the rear leg of a lateral roll bar.

The connection of the lower end of any such diagonal shall be to the opposite backstay at a point no more than 4 inches from its connection to the vehicle structure.

For vehicles with non-strut tower rear suspensions, the lower end of the backstay diagonal may connect to the vehicle body within 6" of the opposite backstay's lower connection to the vehicle.

2.4 Required Element 4 - Main Hoop Diagonal Members

There is a choice of three options within this element.

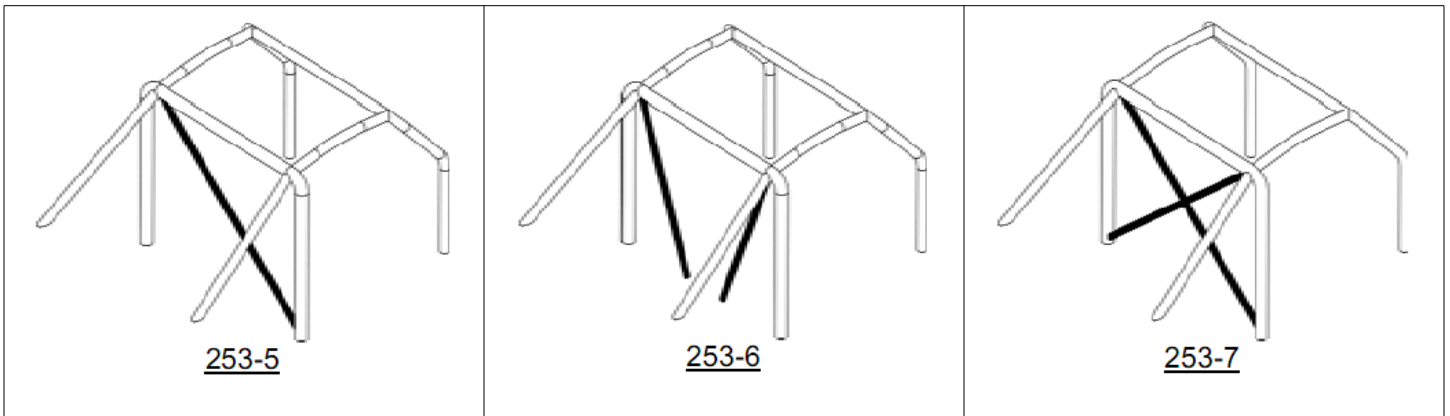

For Choice 253-6 the two halves of the V must be attached to each other and to one continuous reinforcement plate, which is welded on the top of a floor tunnel (not separately to opposite sides of a floor tunnel). A continuous tube is preferred. The level at which each half of the V connects to the main rollbar must be at least 60% of the vertical height of the main rollbar up from the floor plates.

Choices 253-5 and 253-6 both require that a horizontal bar be added. The horizontal bar may be bowed out of the plane of the main hoop. A horizontal bar may be added to Choice 253-7.

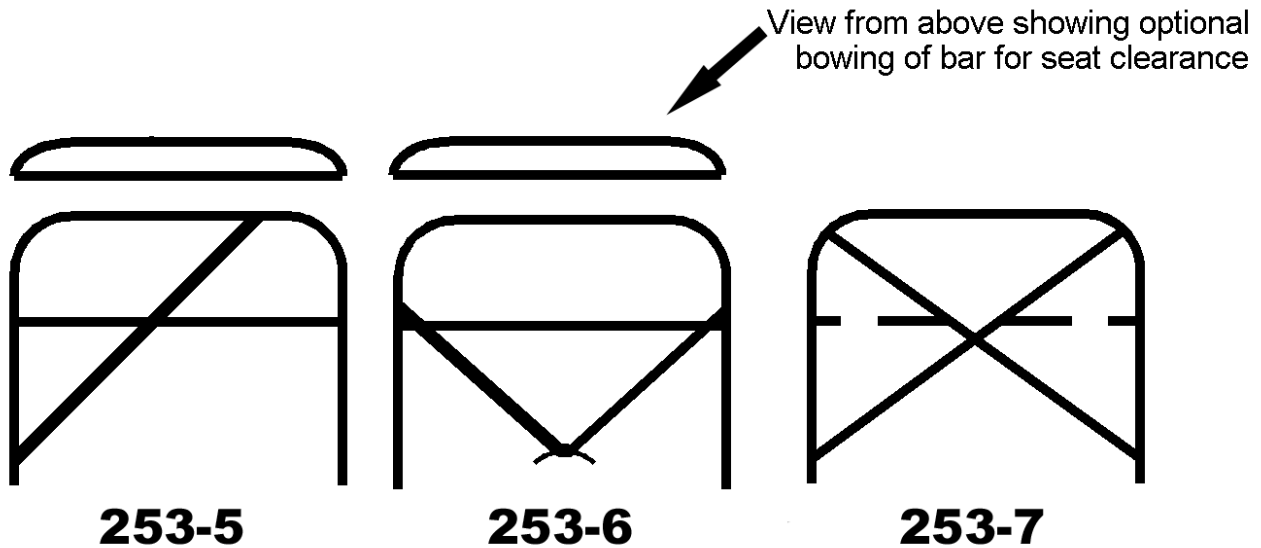

Horizontal Bar Options

The diagonal members must be straight, not curved. A smooth bend at the attachment of the V-configuration to the floor is allowed if this diagonal is made from one continuous tube.

For the X configuration, one of the two cross-members of the X must be a single, continuous tube, with the other cross-member being formed from two half tubes. The joint must have two gussets on opposite sides of the joint to prevent separation of the tubes.

The attachment points of the diagonal members must be located to prevent injuries. The upper end of any diagonal in the plane of the main rollbar, or in the plane of the rear legs of lateral rollbars, must join the main rollbar(s) not further than 4 inches from the junction of the backstay joint, and be as close to the roof level as practical. The lower end of a diagonal for the X- or bar-diagonal configuration must join the main rollbar or lateral roll bars no further than 4 inches from the mounting foot.

2.5 Required Element 5 - Sill bars

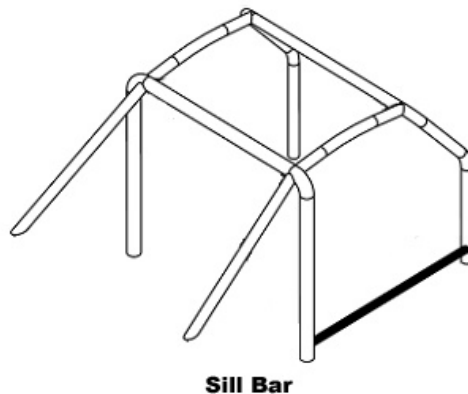

Sill Bars are required in all cars. Sill bars must be welded in place to the main hoop legs and the forward legs of the cage.

Sill bars must be as straight as possible. Bends in the sill bars are often necessary for safe clearance to seats and occupants. Any such bends in the door bars must be completed within 6" of the forward or rear connections of the door bars, so that the majority of the length of the sill bars is straight.

Sill bars should be not more than 4" above the car's door sill as measured to the bottom of the sill bar tubing.

2.6 Required Element 6 - A-pillar reinforcement

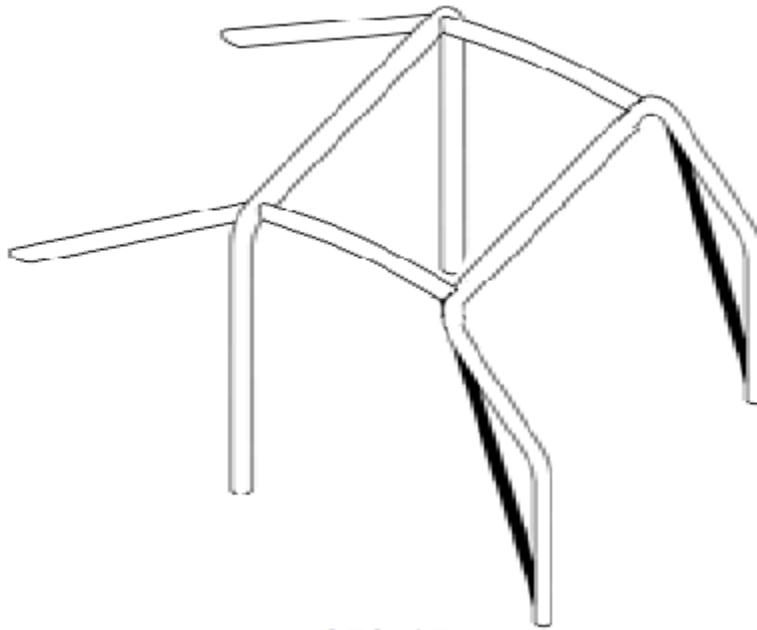

253-15

This reinforcement may be bent only if it remains straight from a side view and the angle of the bend does not exceed 20 degrees. Junctions with the lower mounting point and the upper junction of the lateral half roll bars and transverse member over the windshield, or the front hoop and longitudinal members over the doors, must be less than 4°.

2.7 Required Element 7 - Door Bars

There is a choice of three options within this element.

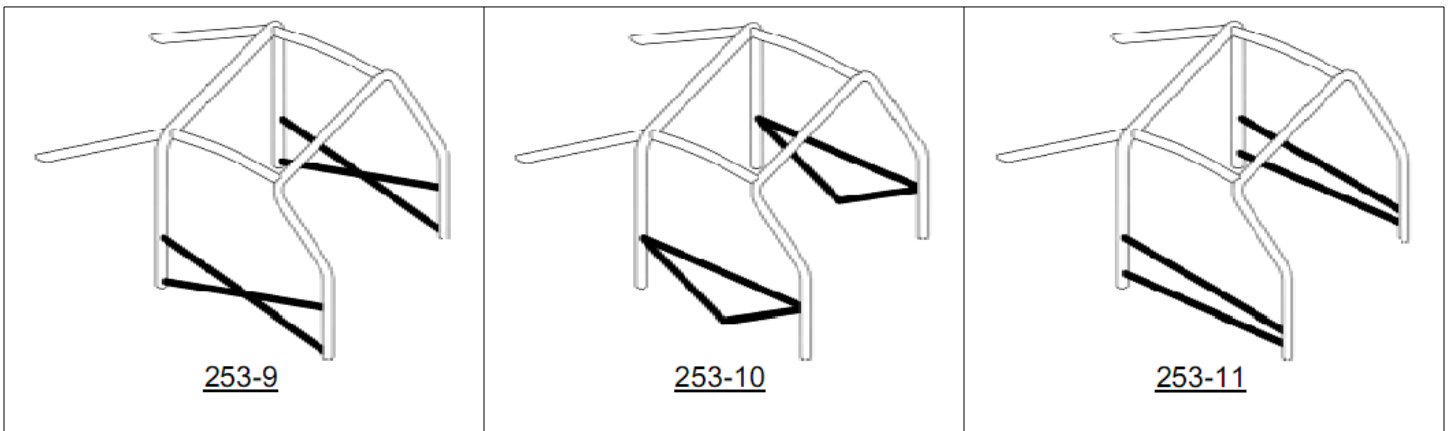

Door bars may be removable, but this is strongly discouraged.

They must be as straight as possible. Any bends in the door bars to allow safe clearance for seat mounts or occupants must be complete within 6" of the forward or rear connections of the door bars, so that the majority of the length of the door bars is straight.

Any attachment point of a door bar to a vertical member of the roll cage must not be higher than half the height of the door opening measured from its base. If these attachment points are located in front of or behind the door opening, this height limitation applies at intersection of the strut and the door opening.

2.7.1 253-9 - X Configuration

There are 2 allowed configurations:

1. It is recommended that the two tubes in an X configuration be formed from two continuous tubes. The upper is formed in the shape of a shallow U, and the lower is formed in the shape of an inverted shallow U. The

connection between these tubes must be welded and have gussets in both the forward and rearward corners of the junction to prevent separation.

2. Alternately, one of the two cross-members of the X should must be a single, continuous tube, with the other cross-member being formed from two half tubes. The connection between these tubes must be welded and have gussets in both the forward and rearward corners of the joint to prevent separation.

It is recommended that the lower attachment points of the X be fixed directly to the intersection of the sill bar and the vertical tubes to which it is connected.

2.7.2 253-10 - V Configuration

The vee bar should be made from one continuous tube. The upper connections of the vee ends to the vertical tubes should be at the joint with the upper horizontal bar.

2.7.3 253-11 - Configuration with single straight bar with sill bar

A single door bar as is allowed. These may be sloped downward from rear to front to improve exiting from the vehicle. For choice 253-11 the Sill Bar can be considered to be the lower of the two bars.

2.7.4 Stock-car style configuration bar

This type of door bar is only allowed in certain circumstances and must be specifically approved by a NASA Rally Sport scrutineer and that approval note in the logbook. There is no guarantee of approval if this is built prior to scrutineer approval.

In cases where the door bar is bent out far enough such that the inner face of the door bar tubing is more than 4" outside of the plane formed by the vertical sections of the main and lateral (or half lateral) roll bars at the A and B pillars, then the door bar tube sizing must meet the requirements set forth below, and 3 braces between the door bar and the sill bar must be included. These braces must be equally spaced in the longitudinal direction between the main hoop and half lateral or front hoop vertical legs (or between the vertical legs if a lateral roll bar design is used). Refer to figure 3.6.2-12.

The tubing for the door bar and the 3 vertical braces must be either 1.5" dia x .120" wall, or 1.75" x .095" wall. (Note that the tubing diameter for door bar and braces used should not exceed the diameter of any tube to which it connects. Thus the 1.75 diameter option can only be used if all the surrounding tubes are 1.75" diameter also.)

3 Optional Reinforcement of the Roll cage

3.1 Optional Reinforcing Members

The following reinforcements are strongly recommended:

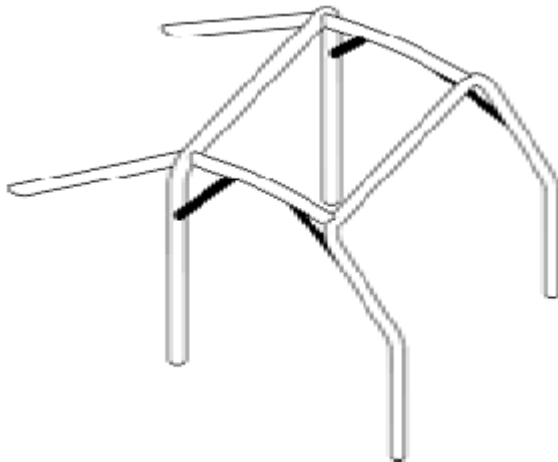

253-31

The ends of these reinforcing tubes for Figure 253-31 must not be more than half way down or along the members to which they are attached, except for those of the junction of the front rollbar, which may join the junction of the door bar and the front leg of the front rollbar, lateral rollbar, or half lateral rollbar. The front elements shown in 253-31 are obsoleted by Element 6 and need not be considered in new construction.

A dash bar (the transverse member fixed to the front rollbar, or between the front legs of lateral rollbars or half rollbars) must not encroach upon the space reserved for the occupants. It must be placed as high as possible but its lower edge must not be higher than the top of the dashboard.

Each type of reinforcement shown in figures 253-16, -17, -18, -20, and 253-25 through 253-33 in Appendix J to the FIA's International Sporting Code, Article 253, are allowed. Refer to that document for those figures. Typical bracing is shown in figure 3.6.2.-14 and -15 below.

3.2 Reinforcement to the Vehicle Body

The cage may be welded to the body at any point. It is strongly recommended to weld the roll cage to the A and B pillars. Use of metal plates to bridge any existing gap is allowed.

3.3 Front core support reinforcement

Extension of the roll cage forward to the strut towers is allowed.

3.4 Trunk area reinforcement

Reinforcement of the rear trunk floor is allowed to better protect trunk mounted fuel cells.

4 Detailed Construction Specifications

4.1 Mounting of Roll cages to the Body shell

4.1.1 Welded Connections

Roll cage tubing must be welded directly to the reinforcement plate. This is the preferred and recommended mounting method. At their terminating points tubes may never be welded directly to the body of the vehicle without a reinforcement plate.

4.1.2 Bolted Connections

The following method of attachment is required:

1. Each mounting foot of the front, main, lateral, and half-lateral rollbars, and of the backstays, must include a mounting foot at least 1/8th inch thick, and a minimum of 3 inches wide and 4 inches long.
 2. Each mounting foot must be attached by at least three bolts on a steel reinforcement plate at least .120" thick and of at least 18 square inches in area which is welded to the body shell.
 3. Examples of mounting feet and reinforcement plates are shown in figures 253-50 to 253-58 of the FIA rules.
 4. Bolts must be of at least M10 or 3/8th inch size. Bolts may be either of ISO Standard 8.8 or Metric Standard 10.9, or SAE grades 5 or 8.
 5. Fasteners must be self-locking or fitted with double nuts. Only flat washers may be used.
- Neither rollbar tubes nor rollbar mounting feet may be welded directly to the body shell without a reinforcement plate.

4.1.3 Reinforcement plates

These are plates welded to the bodyshell used for attachment of the cage, either by direct welding or via mounting feet. Reinforcement plates must be a minimum of 1/8" thick, and have an area of 12 to 100 square inches, with a minimum dimension on any side of 2.5" and a maximum dimension on any side of 12". It is highly recommended that these plates be formed to attach in more than one plane.

4.1.4 Double Through Plating

Double through plating is allowed. The reinforcement plates and car body have holes cut in them allowing the roll cage tube to pass through both. On the exterior of the car, a second reinforcement plate is attached. The roll cage tube is welded twice, once to the interior and once to the exterior plate. The tube must be capped by welding a piece of steel to the end.

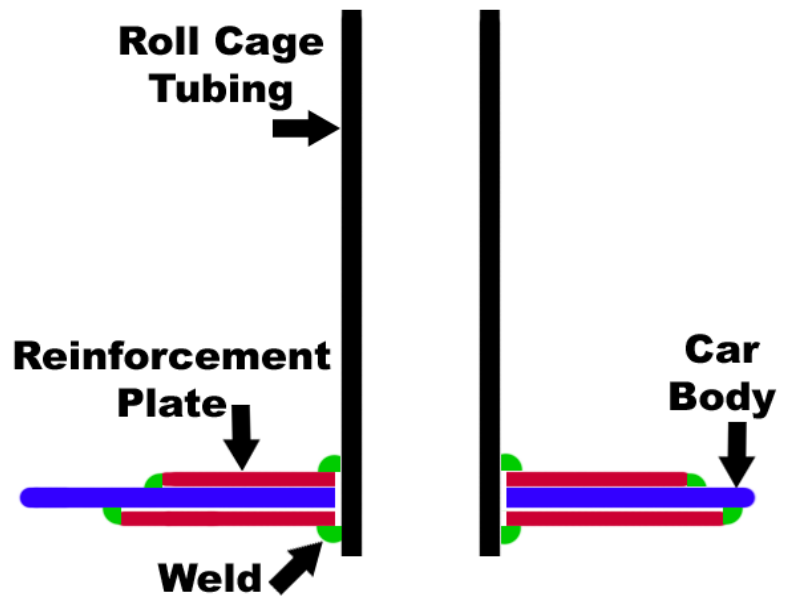

Double Through Plating

4.2 Gusset construction

Gussets are required to be made as follows:

1. U-shaped sheet metal (taco shell). Refer to figure 253-34 below. Minimum thickness is .040" (1 mm). Minimum length along the unwelded side of the gusset is 3 times the tubing diameter.
2. Round tubing. Minimum length of the longest dimensions is 3 times the tubing diameter. Minimum tubing diameter is 1" with minimum wall thickness of .083". Maximum diameter and wall thickness is per the materials in table of section 6.6.
3. One or 2 triangular plate steel gussets with combined thickness equal to the tubing which is being gusseted. Minimum length along the unwelded side of the triangular gusset is 3 times the tubing diameter.

Any plate or u-shaped gusset that is welded into a joint location where it can block the view of the welds between the tubes being reinforced must have the corner cut back to enable visual inspection of the tube joint. This is illustrated in figure 253-34 and typically looks like a bite out of the corner of the gusset.

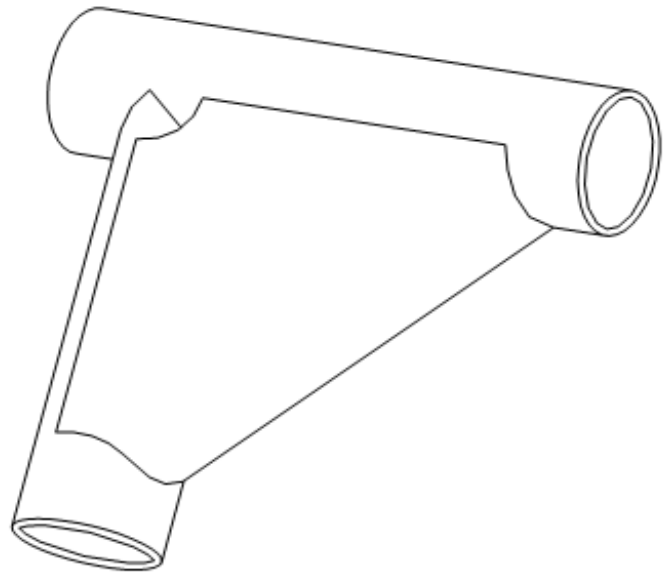

253-34

4.3 Removable Members

Should removable members be used in the construction of a roll cage, the dismantable joints used must comply with a type approved by the FIA. (See FIA International Sporting Code Appendix J, figures 253-37 through 253-47.)

The nuts, bolts, and washers must be of at least M8 or 5/16th inch size, and of ISO Standard 8.8 or Metric Standard 10.9, or SAE grades 5 or 8. Self-locking nuts or double nuts are required to secure nuts. Only flat washers are allowed.

Dismantable joints must not be used for joining the roof level connections between main, front, lateral, or half lateral rollbars because they act as hinges in the principal structure and allow deformation. Their use is solely for attaching diagonal and reinforcing members to the rollbars.

4.4 Guidance on Welding

All welding must be of the highest possible quality with full penetration and preferably using a gas-shielded arc. The welds must be continuous around the whole perimeter of the tube at each joint. The external appearance of a good weld does not necessarily guarantee its quality. However, evidence of poor quality welds by appearance is usually a basis for rejection.

4.5 Cage Tubing Material Requirements

Material: All new cages shall be constructed of either CDS (Cold Drawn Seamless) or DOM (Drawn Over Mandrel) unalloyed carbon steel tubing containing a maximum of 0.3% of carbon and with a maximum content of additives of 1% for manganese and 0.5% for other elements. It is required that mild steel be used for all new cages.

Use of heat-treated or high carbon steels is not allowed after 3/1/2005.

4.6 Cage Tubing Size Requirements

The tubing must be bent by a cold working process and the centerline bend radius must be at least 3 times the tube diameter. If tubing is ovalised during bending, the ratio of minor to major diameter must be 0.9 or greater.

The minimum size of tubing to be used shall be as follows:

Tubing size configuration 1: Allowed for all cars

Size in inches	Size in millimeters	Use

1.75" x 0.095" or 2.0" x 0.083"	45 x 2.5 or 50 x 2.0	Main rollbar (Element 1) Lateral rollbars and their connections (Element 1)
1.5" x 0.095" or 1.6" x 0.083"	38 x 2.5 or 40 x 2.0	Front rollbar and lateral half roll bars, and all other connecting and reinforcement members

Tubing size configuration 2: Allowed for cars weighing 2650 lbs or less, weighed without cage installed and full fuel but without drivers.

Size in inches	Size in millimeters	Use
1.5" x 0.120"	38 x 3.0	Must be used for all portions of the main cage structure including: Main rollbar, front rollbar, lateral rollbars, and lateral half roll bars, and all connecting members at the roof level.
1.5" x 0.095"	38 x 2.5	All other connecting and reinforcement members

5 Protective Padding

5.1 Required Padding

Where the occupants helmets could come into contact with the safety cage, padding to FIA specification 8857-2001, types A or B, or to SFI specification 45.1, must be installed.

5.2 Recommended Padding

Where the occupants bodies could come into contact with the safety cage, padding should be provided for protection. This is particularly important around the areas where the lower legs can contact the cage elements

6 Grandfathering and Variances

Previously logbooked cars (including those with NASA, SCCA, and CARS logbooks) will be allowed to compete as is for this year under the following conditions:

1. The cage must have at least 1 diagonal in the plane of the main hoop (or rear legs of lateral roll bars) and 1 diagonal in the plane of the rear backstays or comply with the diagonal requirements of Element 3 and Element 4.
2. The roof level connections of bolt-in cages are welded per NASA Rally Sport scrutineer guidance. These must be inspected, accepted, and noted in the vehicle logbook at the next event.
3. All cars will be required to have Element 5 (Sill Bars) and Element 7 (Door Bars).
4. All cars without Element 2 (Roof Bars) must have at least one gusset per side at the intersection of the windshield bar and the side half laterals per 4.2. The gusset may be in front of, or behind, the tube across the windshield.

Previously accepted roll cage tubing sizes accepted under SCCA rally rules will be accepted for cars with SCCA logbooks issued prior to Jan 1 2005, for the foreseeable future.

For cars logbooked prior to 1-1-2009, Element 6 (A pillar reinforcements) is not required.

Variations on roll cage designs outside these rules may be accepted at the discretion of the Chief Scrutineer of an event. However, acceptance by the Chief Scrutineer of a non-compliant roll cage at one event does not guarantee continued acceptance at that or any other event, and not to be construed to allow a path for continued acceptance of a non-compliant cage. It strongly recommended that any cage that is given discretionary acceptance for one event be upgraded to be in compliance with these rules rather than have the owner/entrant continue to seek discretionary acceptance at each event.

If a roll cage is found to be not in compliance with rules at an event, but is allowed to compete at the discretion of the Chief Scrutineer at an event, this must be noted in the vehicle logbook. Any corrections required prior to the next event by this logbook notation must be completed or the vehicle will be rejected at the next event.

Previously logbooked cars with a Rally America log book are subject to Rally America grandfathering rules.

7 Documentation and Inspection

Specific roll over protection is subject to the approval of the Scrutineer at each event. Approval is under the guidance provided in these rules, with the condition that the roll cage is presented in a condition of acceptable structural integrity.

Note that roll cages must be inspected after the cage is installed, repaired, upgraded, or modified.

1. For newly assembled rally cars, a logbook will be issued for the specific combination of car and cage.
2. For a car with an existing logbook, for modified or repaired cages, or for a new cage, a log book notation denoting acceptable condition will be made.